



**NETA**

F I S H E R

[www.netafisher.com.tr](http://www.netafisher.com.tr)



**BALIK AVLAMA**  
FISHING



**DALIŞ**  
DIVING



**GÜNÜBİRLİK GEZİ**  
DAILY TRIP



## HAKKIMIZDA

2015 yılında Kemal DERİ tarafından kurulan NETA GEMİ İNŞAA, kendi boyutlarında bulunan tekne sektöründe yapmış olduğu pratik çözümler ve ürün kalitesi yönünden kısa süre içerisinde kendi segmentinde ürün adı olmaktan çıkmış marka haline gelmiştir.

Her sene müşteri ihtiyaçlarını göz önünde bulundurarak eklemiş olduğu çözümlerle, Neta Ailesi' ni daha da genişleterek Aralık 2022'den bu yana Türkiye Kara Suları'nda 980 teknesiyle sektörde hak ettiği yerini almıştır.

Talep ve istekler doğrultusunda hem fiberglass 6.60 teknesi hem de Vakum İnfizyon 7.20 yeni modeliyle yurtiçi ve yurtdışı siz deniz severleri ailesine katmaya karar vermiş olup bu yönde tüm Ar-Ge çalışmalarını eksiksiz yerine getirmiş ve pazarda hak ettiği yeri almak için hazır hale gelmiştir.

## ABOUT US

Founded in 2015 by Kemal DERİ, NETA SHIP CONSTRUCTION has become a brand in its segment in a short time in terms of practical solutions and product quality in the boat sector in its own dimensions.

With the solutions it has added every year by taking into account customer needs, Neta has expanded its family further and has taken its rightful place in the sector since December 2022 with 980 boats in Turkish territorial waters.

In line with the demands and requests, it has decided to add both fiberglass 6.60 boat and Vacuum Infusion 7.20 new model to its family of domestic and international sea lovers and has fulfilled all R&D studies in this direction and has become ready to take its rightful place in the market.



İÇTEN TAKMA MOTORLU MODEL | INBOARD ENGINE MODEL

DIŞTAN TAKMA MOTORLU MODEL | OUTBOARD ENGINE MODE

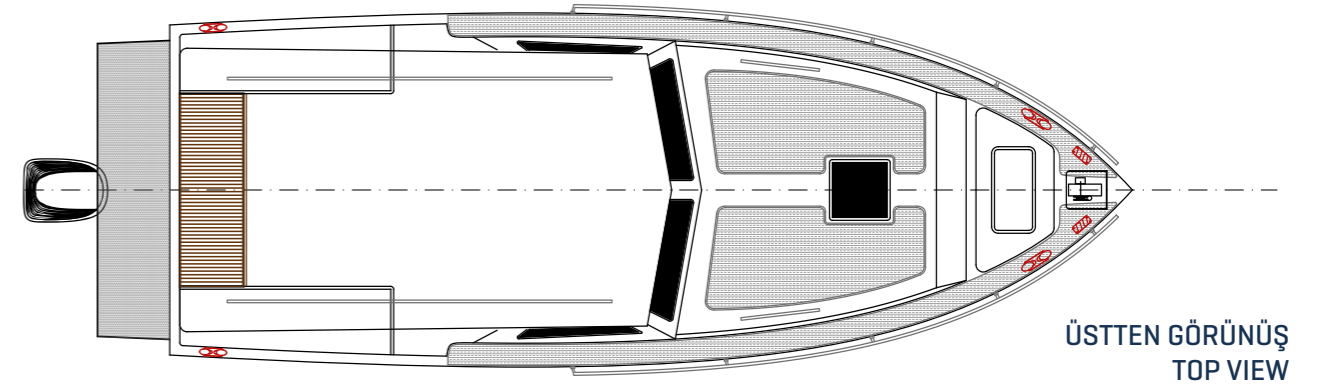
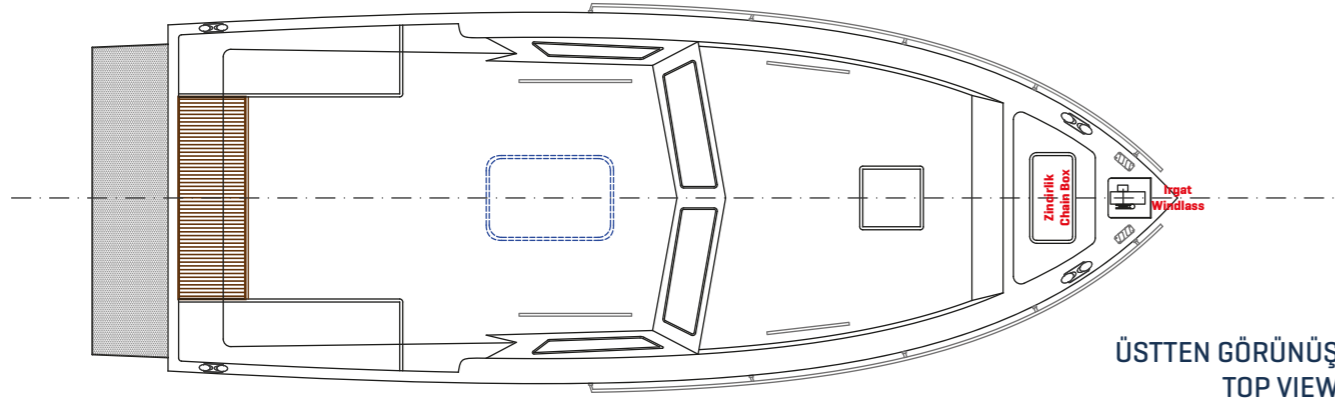
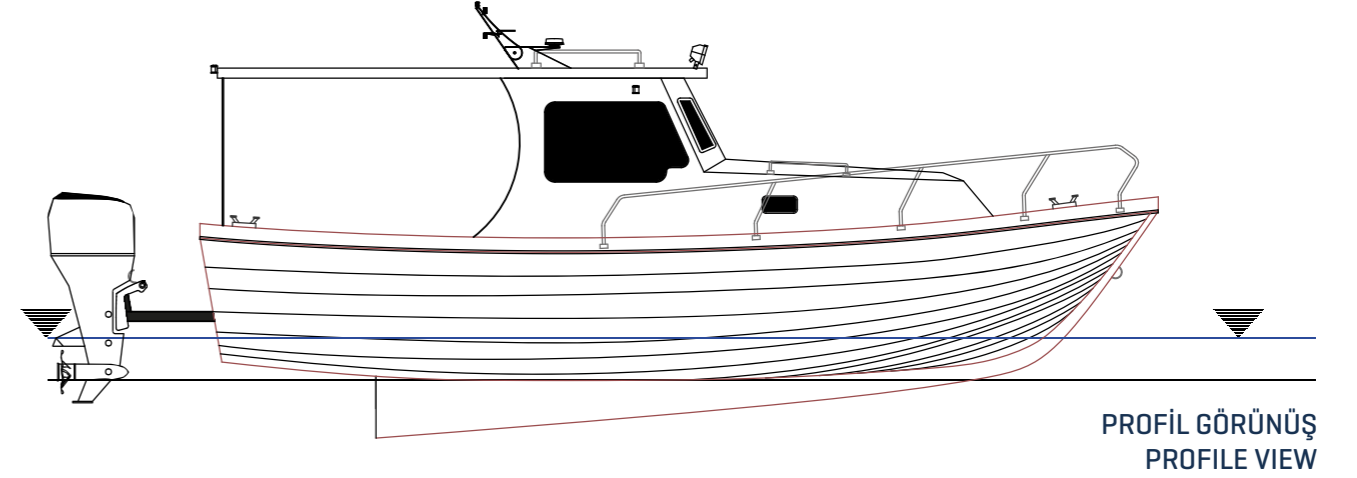
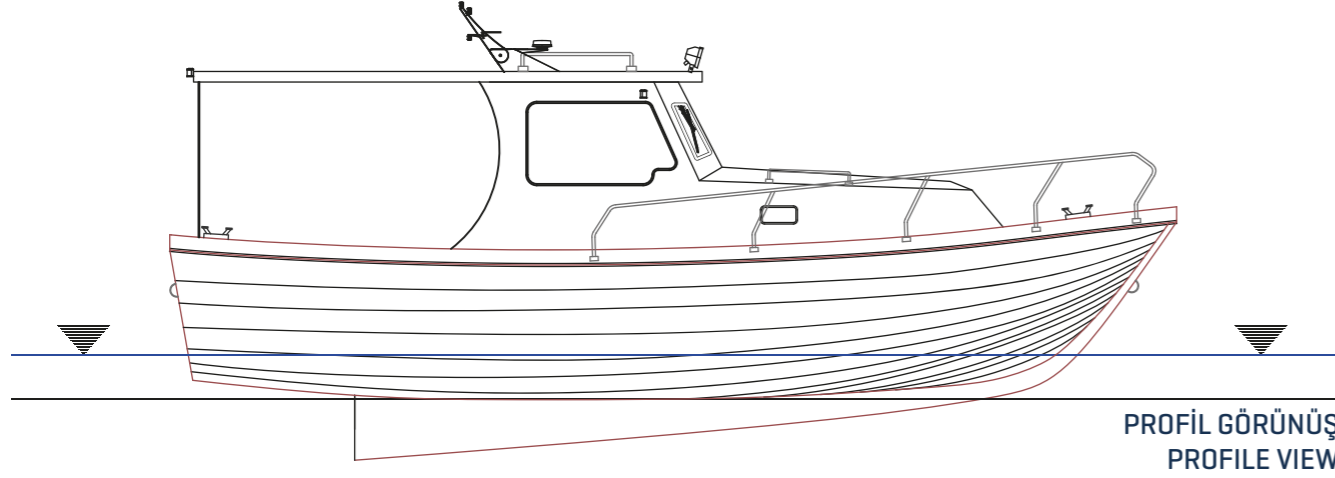

## NETA 6.60 GENEL YERLEŞİM PLANI | NETA 6.60 BOAT LAYOUT PLAN

## TEKNİK ÖZELLİKLER | TECHNICAL SPECIFICATIONS

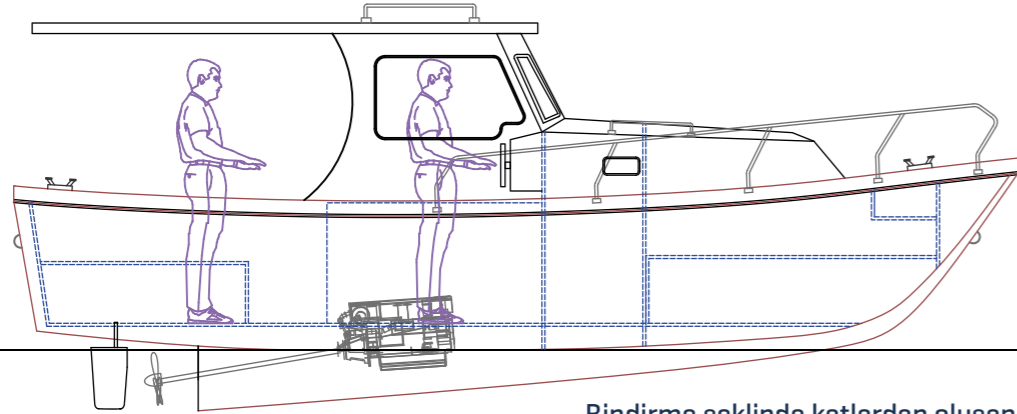

Bindirme şeklinde katlardan oluşan gövde yapısı  
Hull Form

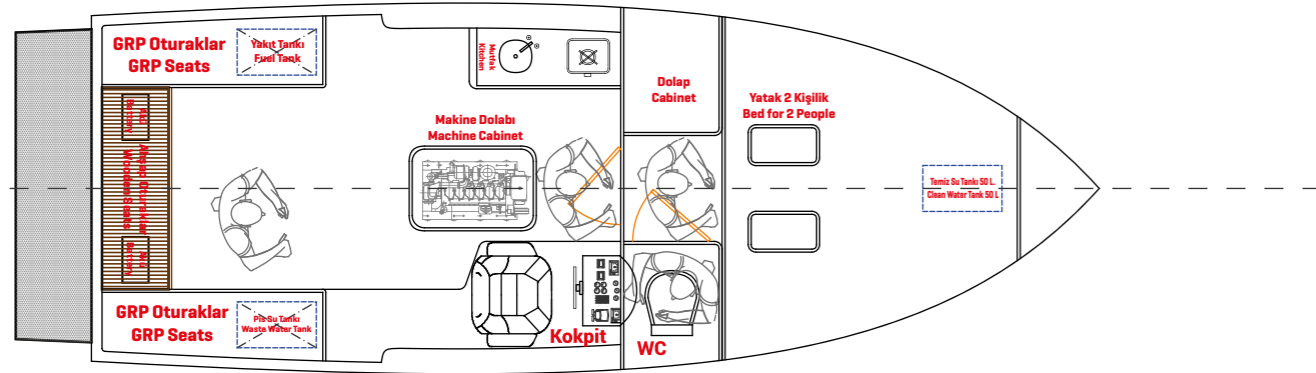

TAM BOY .....	6.66 m
SU HATTI BOYU .....	5.90 m
KALIP GENİŞLİĞİ .....	2.46 m
SU ÇEKİMİ .....	0.70 m
AĞIRLIK .....	1.80 ton (abt.)
MAKİNE GÜCÜ .....	[içten ve dıştan takmalı motor] 20-70 HP
MAX HIZ .....	10 Knots
KAPASİTE .....	6 Kişi
DİZAYN KATEGORİSİ .....	C
YAKIT TANKI KAPASİTESİ .....	50 Lt.
TATLI SU TANKI KAPASİTESİ .....	50 Lt.
PİS SU TANKI KAPASİTESİ .....	50 Lt.
İNŞA MALZEMESİ .....	[Elyaf + Polyester] CAM TAKVİYELİ

Teknenin inşa malzemesi cam elyaf ve polyester reçinedir. İç kısımlarda, gerekli yerlerde gürgen ağacından ahşap takviyeler kullanılmaktadır.

Tekne, 6 kişi kapasiteli olup kıç tarafında 2 adet karşılıklı oturma grubu ve kıç tarafının hemen önünde de 1 adet ahşap oturma grubu yer almaktadır.

Tekne, gerek içten takmalı dizel motorlar ve gerek dıştan takmalı benzinli motorların kullanımına uygun bir tasarıma sahiptir.

Tekne üzerinde, kamaraların üzerinde, kamaraların yanlarında ve gövde üzerinde dıştan monte edilmiş krom tutamaklar bulunmaktadır.

Tekne kıçtan takmalı 50 - 90 HP gücündeki gerek benzinli ve gerekse de elektrikli motorlar ile sevk ve tahrik edilebilecek şekilde tasarlanmıştır.

Teknenin kamarasının girişinde, kaptan koltuğunun yan tarafında ve merkez hattı üzerinde 1 adet kilitli kapı yer almaktadır.

Kaptan koltuğu ve mutfak bölümlerinin yer aldığı kapalı mahal in ön ve yanlarında camlar bulunmaktadır.

Tekne, 1.800 kg ağırlığa ve tam yüklü durumda yüzerken de 0.70 metre su çekimine sahip olacak şekilde tasarlanmıştır.

FULL SIZE .....	6.66 m
WATER LINE LENGTH .....	5.90 m
MOLD WIDTH .....	2.46 m
WATER WITHDRAWAL .....	0.70 m
WEIGHT .....	1.80 tons (abt.)
MACHINE POWER .....	[inboard and outboard engine] 20-70 HP
MAX SPEED .....	10 Knots
CAPACITY .....	6 Person
DESIGN CATERGORY .....	C
FUEL TANK CAPACITY .....	50 Lt.
FRESH WATER TANK CAPACITY .....	50 Lt.
HOLDING TANK .....	50 Lt.
BUILDING MATERIAL .....	[Fiber + Polyester] GLASS REINFORCED

The construction material of the boat is glass fiber and polyester resin. In the interior, wooden reinforcements made of hornbeam are used where necessary.

The boat has a capacity of 6 people and there are 2 opposite sitting groups at the stern and wooden sitting group just in front of the stern.

The boat has a design suitable for the use of both inboard diesel engines and outboard gasoline engines.

There are chrome handles mounted externally on the boat, on the cabins, on the sides of the cabins and on the hull.

The boat is designed to be propelled and driven by either gasoline or electric motors with a power of 50-90 outboard.

There is locked door at the entrance of the cabin of the boat, on the side of the captain's seat and on the center line.

There are windows on the front and sides of the closed space where the captain's seat and kitchen sections are located.

The boat is designed to weigh 1.800 kg and have a draft of 0.70 meters when floating when fully loaded.









## STANDART MALZEMELER VE DONANIM LİSTESİ

- |                                |         |
|--------------------------------|---------|
| • 50 Lt TEMİZ SU TANKI         | 1 ADET  |
| • MERMER LAVABO                | 1 ADET  |
| • 90 AH AKÜ                    | 2 ADET  |
| • 90 Lt BUZDOLABI              | 1 ADET  |
| • 340 W GÜNEŞ ENERJİSİ PANELİ  | 2 PANEL |
| • SU ALTI AYDINLATMA LAMBASI   | 2 ADET  |
| • SUNBRELLA PLUS KIŞLIK BRANDA |         |

## STANDARD MATERIALS AND HARDWARE LIST

- |                                |         |
|--------------------------------|---------|
| • 50 Lt CLEAN WATER TANK       | 1 PIECE |
| • MARBLE SINK                  | 1 PIECE |
| • 90 AH BATTERY                | 2 PIECE |
| • 90 Lt FREEZER                | 1 PIECE |
| • 340 W SOLAR PANEL ENERGY     | 2 PANEL |
| • UNDERWATER LIGHTINGS         | 2 PIECE |
| • SUNBRELLA PLUS WINTER CANVAS |         |







## OPSİYONEL MALZEMELER VE DONANIM LİSTESİ

- 50 LT İLAVE SU TANKI
- 140 LT GÖSTERGİLİ KROM SU TANKI
- WEBASTO
- ÖN PLATFORM
- KAPLAMALI ARKA PLATFORM
- MOBİLYA KAPTAN KOLTUĞU
- KATLANIR TELEKOPIK MASA
- SAHİL BESLEME SİSTEMİ
- ELEKTRİKLİ WC
- KAPTAN ÜZERİ AÇILIR HAVALANDIRMA
- İLAVE KABİN DOLABI
- KABİN YAN RAFLARI
- YATAK İLAVESİ
- VARDAVELA FİLESİ
- MERDİVEN LAMBASI [3 ADET]
- MOBİLYA FARKI
- DENİZ SUYU DEVRESİ
- WC İÇİN KAPALI ALAN
- GÜNEŞLENME MİNDERLERİ
- ÇİFTLİ OCAK
- İNVERTÖR
- TEYP + HOPARLÖR SİSTEMİ
- BALIK BULUCU
- ARKA MİNDER
- İLAVE LUMBOZ
- İLAVE TUTACAK

## OPTIONAL MATERIAL AND HARDWARE LIST

- 50 LT ADDITIONAL WATER TANK
- 140 LT CHROME WATER TANK WITH DISPLAY
- WEBASTO
- FRONT PLATFORM
- REAR PLATFORM COATED
- FURNISHED CAPTAIN ARMCHAIR
- FOLDING TELECOPIK TABLE
- BEACH FEED
- ELECTRIC WC
- ABOVE CAPTAIN VENTILATION
- CABIN ADDITIONAL CABINET
- CABIN SIDE SHELVES
- ADDITIONAL BEARING BED
- VARDAVELA NETWORK
- LADDER LAMP [3 ADET]
- FURNITURE DIFFERENCE
- SEA WATER CIRCUIT
- WC CLOSED AREA
- SUNBATHING MATTRESS
- DOUBLE COOKER
- INVERTOR
- TEYP + SPEAKER SYSTEM
- FISH FINDER
- BACK CUSHION
- ADDITIONAL PORT [LUMBOZ]
- ADDITIONAL HANDLE



SERTİFİKALAR | CERTIFICATES







Torasan Mh. Pınardere Sok.  
35430 No:2 Urla - izmir

T/F: +90 553 111 11 35

info@netafisher.com.tr

kemal@netafisher.com.tr

kyildirim@netafisher.com.tr

emirhan@netafisher.com.tr

enise@netafisher.com.tr

[www.netafisher.com.tr](http://www.netafisher.com.tr)

